

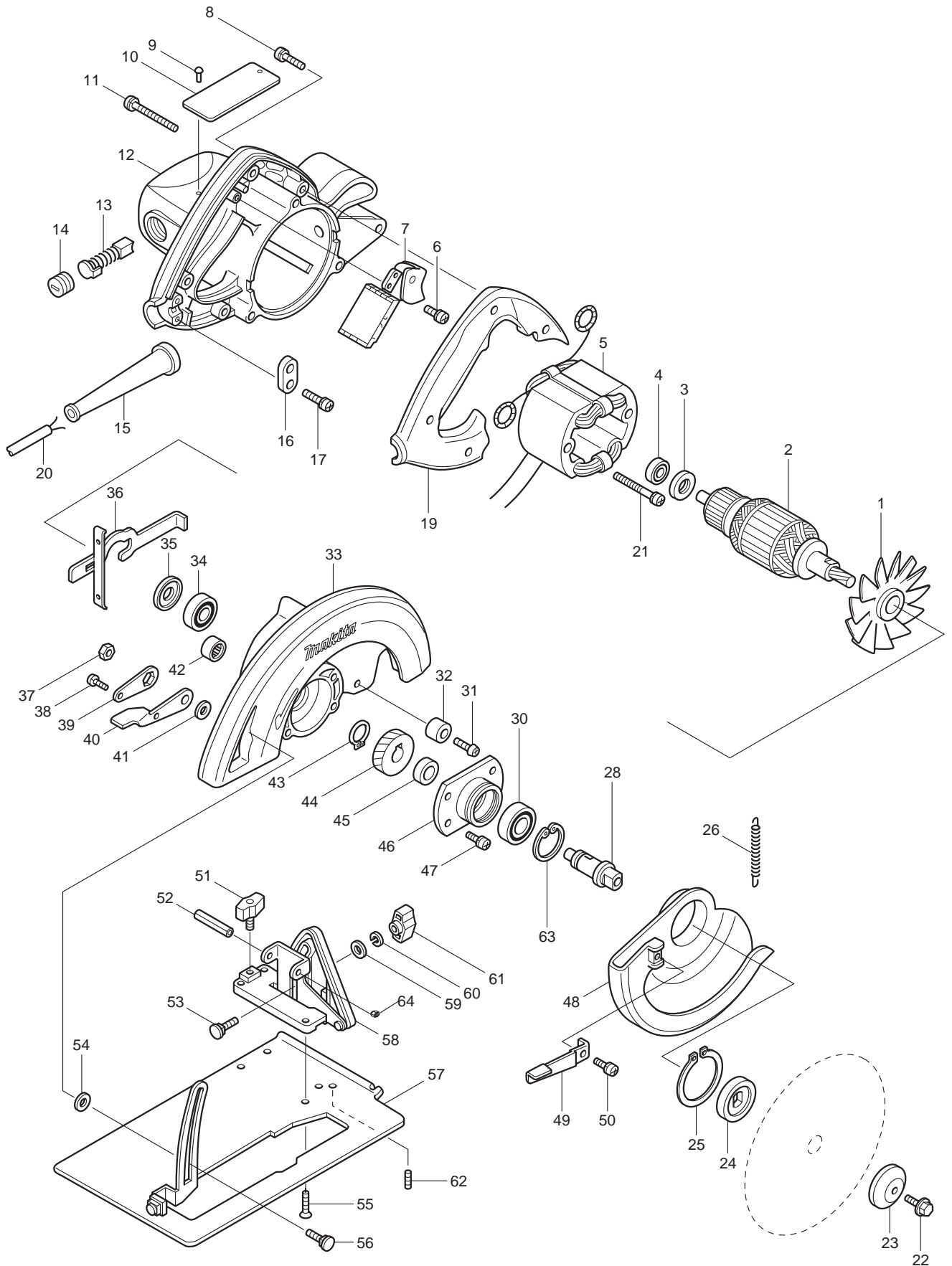

06 - 2011  
5007NB (MKC)  
(Made in China)  
7-1/4" CIRCULAR SAW, AC/DC



Item No.	Type	Sub	Part No.	Description	Q'ty	Unit
001			241513-4	FAN 92	1	PC.
002			510057-8	ARMATURE ASS'Y 115V	1	PC.
		INC.		Item No. 1,3,4,34,35		
003			681625-5	INSULATION WASHER	1	PC.
004	2		210005-4	BALL BEARING 608DDW	1	PC.
005	2		596396-0	* FIELD ASS'Y 115V	1	PC.
		INC.	654020-2	* RING TERMINAL	2	PC.
		INC.	654553-7	* CONNECTOR 34137	2	PC.
006			266020-6	* TAPPING SCREW 4X12 (Removed after Feb 2014 production)	1	PC.
007			651172-0	SWITCH TG933TN-1	1	PC.
008			265995-6	TAPPING SCREW 4X18	4	PC.
009			953106-2	RIVET 0-5	2	PC.
010			853470-0	NAME PLATE 5007NB	1	PC.
011			911273-9	PAN HEAD SCREW M5X50	3	PC.
012	1		141120-2	* MOTOR HOUSING COMPLETE	1	PC.
		INC.	643653-8	* BRUSH HOLDER 6.5-13.5	2	PC.
		INC.	817422-5	* CAUTION LABEL ENG FR	1	PC.
	2		142466-9	* MOTOR HOUSING COMPLETE	1	PC.
		INC.	643653-8	* BRUSH HOLDER 6.5-13.5	2	PC.
013			194986-9	CARBON BRUSH CB-154 2PC/SET W/ ORIGIN	1	SET
014			643650-4	BRUSH HOLDER CAP 6.5-13.5	2	PC.
015	2		682574-9	* CORD GUARD 10-90	1	PC.
016	2		687124-5	STRAIN RELIEF	1	PC.
017			265995-6	TAPPING SCREW 4X18	2	PC.
019	2		454973-3	* HANDLE COVER	1	PC.
020			664463-0	CORD WITH PLUG 2P-14-2.5M, SJ	1	PC.
021			266046-8	TAPPING SCREW 5X50	2	PC.
022			251644-1	HEX. FLANGE HEAD BOLT M8X20	1	PC.
023			224275-9	OUTER FLANGE 40	1	PC.
024			224151-7	INNER FLANGE 40	1	PC.
025			961201-4	RETAINING RING S-42	1	PC.
026	1		231828-7	* TENSION SPRING 4	1	PC.
	2		231888-9	* TENSION SPRING 4	1	PC.
028			324256-4	SPINDLE	1	PC.
030			211206-7	BALL BEARING 6202LLB	1	PC.
031			251247-1	+ PAN HEAD SCREW M6X20	1	PC.
032			262502-6	RUBBER SLEEVE 6	1	PC.
033	2		142465-1	* BLADE CASE COMPLETE	1	PC.
		INC.	213459-4	* O RING 32	1	PC.
		INC.		* Item No. 42		
	3		140H40-5	* BLADE CASE COMPLETE	1	PC.
		INC.	213459-4	* O RING 32	1	PC.
		INC.		* Item No. 42		
034			211106-1	BALL BEARING 6201LLB	1	PC.
035			213102-5	DUST SEAL 12	1	PC.
036			163113-9	SPINDLE LOCK	1	PC.
037			931402-8	HEX. NUT M8	1	PC.
038			911106-8	PAN HEAD SCREW M4X8	1	PC.
039			341415-5	LOCK PLATE	1	PC.
040			341416-3	LEVER PLATE	1	PC.
041			941201-0	FLAT WASHER 8	1	PC.
042			212052-1	NEEDLE BEARING 1010	1	PC.
043			961055-9	RETAINING RING S-15	1	PC.
044			226532-1	HELICAL GEAR 39	1	PC.
045			257064-7	RING 15	1	PC.
046			316700-5	BEARING BOX	1	PC.
047			911126-2	PAN HEAD SCREW M4X16	4	PC.
048			317436-9	SAFETY COVER	1	PC.

Item No.	Type	Sub	Part No.	Description	Q'ty	Unit
049			341417-1	LEVER	1	PC.
050			266026-4	TAPPING SCREW BIND CT 4X12	1	PC.
051			251858-2	SCREW M6X15	1	PC.
052			265075-8	+ PAN HEAD SCREW M5	1	PC.
053			251920-3	CAP SQUARE NECK BOLT M6X30	1	PC.
054			267113-2	FLAT WASHER 12	1	PC.
055			912212-2	COUNTERSUNK HEAD SCREW M5X12	4	PC.
056			266249-4	CAP SQUARE NECK BOLT M8X24	1	PC.
057			163378-3	BASE	1	PC.
058			163248-6	ANGULAR PLATE	1	PC.
059			941151-9	FLAT WASHER 6	1	PC.
060	2		253428-3	SPRING WASHER 6	1	PC.
061			252624-0	WING NUT M6	1	PC.
062			266213-5	H.S.SET SCREW(FLAT POINT)M5X12	1	PC.
063			962153-2	RETAINING RING R-35	1	PC.
064			252103-8	HEX. LOCK NUT M5-8	1	PC.
070	2		417711-4	* BUFFLE PLATE	1	PC.
072			810133-1	CAUTION LABEL	1	PC.
100			652008-6	PAN HEAD SCREW M3.5X7	4	PC.
101	2		654037-5	* TERMINAL R1.25-3.5	2	PC.
102	2		654077-3	* TERMINAL 2-S3	2	PC.
C01			872352-7	CARTON	1	PC.
<b>ACCESSORIES</b>			<b>- See Catalogue or visit <a href="http://www.makita.ca">www.makita.ca</a> for more accessories -</b>			
A01			164095-8	GUIDE RULE	1	PC.
A02			782016-4	OFFSET WRENCH 13	1	PC.
A03	2		D-51138	7-1/4" C.T.SAW BLADE 24T	1	PC.
	Opt		D-35352-10	7-1/4" C.T.SAW BLADE 24T, 10/SE	1	SET
	Opt		A-94839-10	7-1/4" FRAMING BLADE 24T, 10/SE	1	PC.
A04			824473-1	PLASTIC CARRYING CASE (BLOW)	1	PC.
		INC.	417059-4	LATCH	2	PC.
		INC.	418889-6	HANDLE	1	PC.
A05			199711-3	DUST NOZZLE SET	1	PC.
		INC.	272243-5	LEVER 36	1	PC.
		INC.	911223-4	PH SCREW M5X16 W/WR	1	PC.

**SERVICE CHANGES**

**1. Changes on Tension Spring 4**

(TI#A3885)

Item No.	Description	Type 1	Type2
26	Tension spring 4	231828-7	231888-9

Type 1



Spring pulling force: 4.0N

Type 2



Spring pulling force: 4.9N

**Note:** When replacing Tension spring 4, apply 0.05ml of Lubricant VG46 on Drum portion of Bearing box where Safety cover pivots as illustrated below.

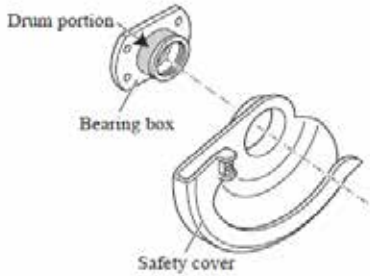

**2. Changes on Motor Housing etc.**

(TI#A2015)

Item No.	Description	Type 1	Type2	Fig no.
33	BLADE CASE COMPLETE	153436-3	142465-1	1), 2)
12	MOTOR HOUSING COMPLETE	141120-2	142466-9	3)
19	HANDLE COVER	416889-0	454973-3	4)
6	TAPPING SCREW 4X12	266020-6		
70	BUFFLE PLATE	418888-8	417711-4	6)
103	VINYL TUBE 8-10-60	683006-9		
5	FIELD ASS'Y 115V	596066-1	596396-0	
101	TERMINAL R1.25-3.5	654001-6	654037-5	
15	CORD GUARD 10-90	682505-8	682574-9	
102	TERMINAL 2-S3	654004-0	654077-3	5)

Interchangeable as a set

Fig. 1)

Change of Blade case complete

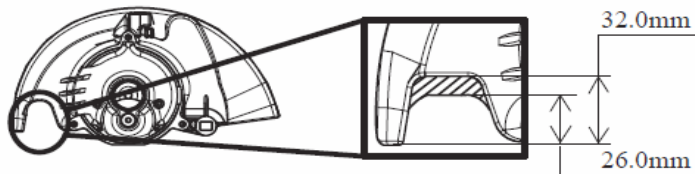

Height of opening to see blade tip has been reduced from 32.0mm to 26.0mm.

Fig. 2) Change of Indication label

	Current	New
Design		
Pasting position		

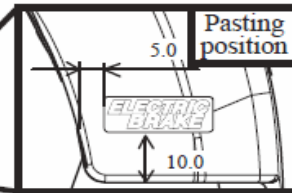

**Fig. 3)**

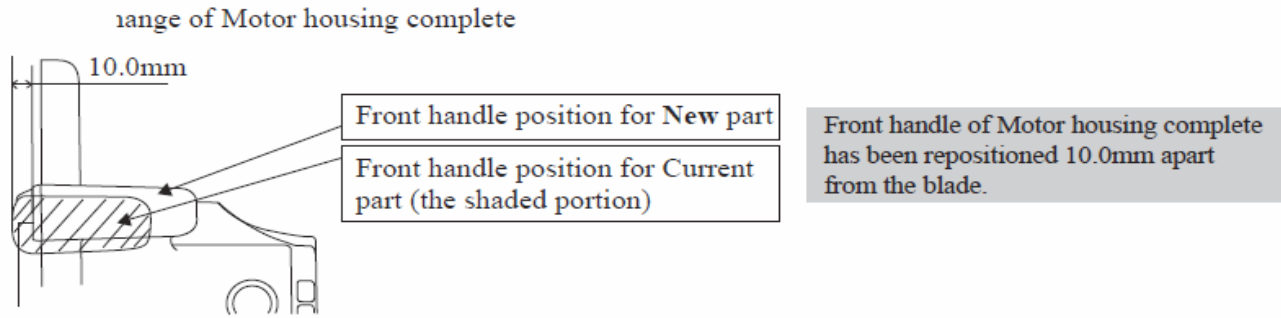
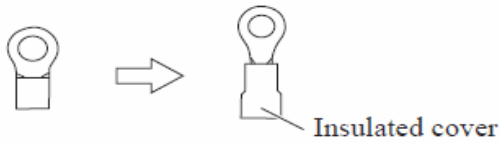

**Fig. 4)**

Change of Handle cover (for 5007NB)



**Fig. 5)** Change of Terminal



**Fig. 6)** Change of Baffle plate

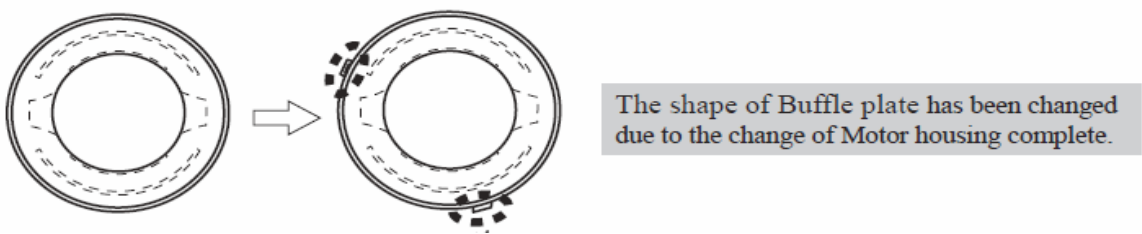

Wiring Diagram : See TI#A2015